

Quincalux

HANDLING LUXURY SINCE 1942

DISTRIBUE PAR

ARTI
DESIGN

Christian SCELLES

Ch.scelles@artidesign.eu

Tel : 06 14 62 64 93

Architectural Hardware

Contemporary Collection 2024 - 2025

Q 1942



HANDLING LUXURY SINCE 1942

At Quincalux, we have been inspiring Architecture with Craftsmanship since 1942. For eighty years we have been blending tradition and innovation, made by hand in Belgium, with a never-ending search for improving techniques. Driven by quality, we solely craft our door handles into timeless designs with noble materials such as brass and aluminium as these age perfectly and are sustainable, a characteristics which we keep close to heart. Today, our product range extends in two directions : a traditional Classic Collection and an innovative Contemporary Collection.

Chez Quincalux, nous inspirons l'architecture par notre savoir-faire artisanal depuis 1942. Depuis quatre-vingts ans, nous allions tradition et innovation, fabrication à la main en Belgique et recherche permanente d'optimisation de nos techniques. Passionnés par la qualité, nous réalisons uniquement des poignées de porte au design intemporel avec des matériaux nobles tels que le laiton et l'aluminium, qui vieillissent parfaitement et sont durables, un aspect qui nous tient particulièrement à cœur. Aujourd'hui, notre gamme de produits est axée vers deux directions : une collection classique traditionnelle et une collection contemporaine placée sous le signe de l'innovation.



Photography: Kristof Delbart

Four generations of Belgian craftsmanship

Design and craftsmanship, hand-made in Belgium. Quincalux guarantees traditional craftsmanship with modern technological ingenuity. Every part turned, milled hot-pressed or cast in a sand bed is considered and detailed with care and passion for the craft. From the crank pin to the adjusting bolt; from the groove to the handle, it is always the result of a meticulous design and production process. Cutting-edge innovative technology helps polish the true métier, but the hand always comes first at Quincalux. The knowledge is at hand and passed on from generation to generation. Every new product created by designers for architects always passes through many hands.

That's what it's always meant for.

Quatre générations d'artisanat belge

Design et artisanat, fabrication à la main en Belgique. Quincalux garantit un artisanat traditionnel combiné à l'ingéniosité technologique moderne. Chaque pièce tournée, fraisée, pressée à chaud ou coulée dans un lit de sable est manipulée et détaillée avec soin et passion pour le métier. Du maneton à la vis de réglage, de la rainure à la poignée, le processus de conception et de production est toujours appliqué dans le souci du détail. Une technologie innovante de pointe soutient le vrai métier, mais Quincalux privilégie toujours le travail à la main. Notre savoir spécifique se transmet de génération en génération. Chaque nouveau produit créé par des designers pour des architectes passe toujours par plusieurs mains avant validation.

L'objectif pour lequel il est initialement conçu.

Cannes
20



Helsinki
40



Como
62



Royal
88



Lisbon
106



Q-Line 703
120



London
22



Athena
46



Palma
68



Stockholm
92



Madrid
108



Q-Line 704
121



Paris
24



Copenhagen
52



Oslo
74



Luxembourg
96



Brussels
112



Accessoires
122



Antwerp
30



Cassis
58



Lausanne
78



Berlin
100



Q-Line 700
118



Patines / Finishes
127

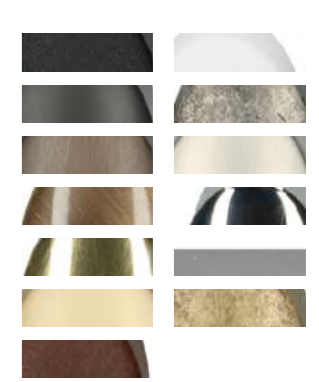

Imperial
34



Monaco
60



Montreux
82



Luxor
104



Q-Line 701
119



Design Driven

Quincalux is proud to work with internationally renowned designers, architects and interior architects for the creation of their new collections.

They are supported by the internal development team and the creative director, Frederik Delbart.

Axé sur le design

Quincalux collabore avec des designers, des architectes et des architectes d'intérieur à la renommée internationale pour la création de ses nouvelles collections.

Ils sont soutenus par l'équipe de développement interne et par le directeur créatif, Frederik Delbart.



Cas Moor & Lieven Musschoot

Jeffrey Huyghe

Julien Renault

Frederik Delbart



Imperial



FREDERIK DELBART

Creative Director & Designer
2018 Belgian Designer Of The Year

www.frederikdelbart.com

Frederik Delbart's interdisciplinary approach includes product design as well as strategic design management and creative direction. After his studies at La Cambre Arts Visuels, his career took off. This is demonstrated by numerous product introductions, several awards as well as long-term strategic partnerships with companies. Since 2015, he has been active as Creative Director for Quincalux, collaborating closely with the direction and setting the lines for future strategy, collections and branding and bringing the company's brand to the next level.

In 2018, Delbart was awarded the prestigious title of 'Belgian Designer of the Year'. He's internationally acclaimed for his thoughtful design philosophy, in which nothing is left to chance. From concept to design and from use of materials over production process to implementation, marketing and branding, even the subsequent logistics chain does not escape his attention. The collections from his hand are London, Paris, Antwerp, Cannes, Caracas, Quito, Oslo, Royal, Imperial, Copenhagen, Athena, Kyoto and Osaka.

L'approche interdisciplinaire de Frederik Delbart comprend le design de produits ainsi que la gestion stratégique du design et une direction créative. Après ses études à La Cambre Arts Visuels, sa carrière a pris son envol. En témoignent de nombreuses introductions de produits, plusieurs prix ainsi que des partenariats stratégiques à long terme avec des entreprises. Depuis 2015, il endosse le rôle de directeur créatif pour Quincalux, en étroite collaboration avec la direction. Il établit la stratégie, les collections et le branding, et élève la marque de l'entreprise à un niveau supérieur.

En 2018, Frederik Delbart s'est vu attribuer le prestigieux titre de Designer belge de l'année. Il est également reconnu au niveau international pour sa philosophie de conception réfléchie, dans laquelle rien n'est laissé au hasard. Du concept au design et de l'utilisation des matériaux au processus de production en passant par la mise en œuvre, le marketing et le branding, même la chaîne logistique ultérieure n'échappe pas à son attention. Il a notamment conçu les collections London, Paris, Antwerp, Cannes, Caracas, Quito, Oslo, Royal, Imperial, Copenhagen, Athena, Kyoto et Osaka.



Palma



JULIEN RENAULT

Designer

2023 Belgian Designer Of The Year

Julien Renault grew up outside Paris and attended design schools both in France (Reims School of Art and Design) and in Switzerland (ECAL). Two different cultures and approaches to design which have partly shaped Renault's own way of addressing his work. On the one hand artistic, free and personal, on the other hand systemic, objective and rational. Renault uses both pragmatism and intuition when he dives into a new project, creating a dialogue between sense and sensibility. The cross-disciplinary output is suitable for a designer such as Renault who is grounded in his vision of essentialism. Behind each apparently plain project lurks a bunch of well-considered references and the mindset of a designer who leaves nothing to chance. Renault thinks and works conceptually and throughout each project follows a precise and recognisable image. Whether the assignment is a product design, a photo shoot or an interior space, it starts with a defining element which accompanies the concept from start to finish. For Quincalux he created the Palma Collection.

Julien Renault a grandi en région parisienne et a fréquenté des écoles de design en France (École Supérieure d'Art et de Design de Reims) et en Suisse (ECAL), deux cultures et deux approches différentes du design qui ont contribué à façonner la manière dont Renault aborde son travail. D'un côté artistique, libre et personnel, de l'autre systémique, objectif et rationnel. Renault se sert de son pragmatisme et de son intuition lorsqu'il se plonge dans un nouveau projet, créant ainsi un dialogue entre le sens et la sensibilité. Cette approche interdisciplinaire convient à un designer tel que Renault, ancré dans sa vision de l'essentiel. Derrière chaque projet en apparence banal se cache un ensemble de références réfléchies et l'état d'esprit d'un designer qui ne laisse rien au hasard. Renault pense et travaille de manière conceptuelle et chaque projet suit une image précise et reconnaissable. Qu'il s'agisse d'un design de produit, d'une séance photo ou d'un espace intérieur, tout commence par un élément déterminant qui accompagne le concept de A à Z. Il a créé pour Quincalux la collection Palma.

www.julienrenaultobjects.com



JEFFREY HUYGHE

Designer

Jeffrey Huyghe graduated as an industrial product designer at Howest, Kortrijk. With a heart for engineering, Jeffrey likes to experiment with geometrical shapes and dynamic interactions. This translates in an interesting tension where minimalism and materialisation meet state-of-the-art engineering.

Examples are multi-awarded architectural lighting designs like Semih (2016) and Marbul (2018) where complex hidden rotational systems are disguised as pure designs. Recently he started his own studio where, beyond lighting, he can push further the boundaries of the interaction between materials and mechanics. The Helsinki Collection was designed by Jeffrey Huyghe.

Jeffrey Huyghe est diplômé en tant que designer de produits industriels à Howest, Courtrai. Avec un cœur pour l'ingénierie, Jeffrey aime expérimenter les formes géométriques et les interactions dynamiques. Cela se traduit par une tension intéressante où minimalisme et matérialisation rencontrent une ingénierie de pointe.

Des exemples sont des conceptions d'éclairage architecturales multi-primées comme Semih (2016) et Marbul (2018) où des systèmes de rotation cachés complexes sont déguisés en conceptions pures. Il a récemment créé son propre studio où, au-delà de l'éclairage, il peut repousser les limites de l'interaction entre les matériaux et la mécanique. La collection Helsinki a été conçue par Jeffrey Huyghe.

www.jeffreyhuyghe.com

Helsinki



Como



LIEVEN MUSSCHOOT & CAS MOOR

Interior Architect & Designer

Interior architect Lieven Musschoot has an impressive track record in the field of hospitality projects. In the many trendy bars and acclaimed restaurants, he always manages to add a new dimension to the concept of 'tasteful design'. No detail goes unnoticed.

Since 2014, he has also been reinforced by Cas Moor, a pur sang product designer. Together the duo develops complete projects, from interiors to custom lighting, furniture and accessories.

LMCM designed the Como collection for Quincalux, in which you can experience the grandeur of the famous Alpine lake.

L'architecte d'intérieur Lieven Musschoot peut se targuer de posséder un palmarès impressionnant dans le domaine des projets d'accueil. Mieux que quiconque, il sait toujours ajouter une nouvelle dimension au concept de « design de bon goût » dans les nombreux bars branchés et restaurants de renom. Aucun détail ne passe inaperçu.

En 2014, il a été rejoint par Cas Moor, un designer de produits pure souche. Ensemble, le duo développe des projets complets, des intérieurs aux luminaires sur mesure, en passant par le mobilier et les accessoires.

LMCM a conçu la collection Como pour Quincalux, qui respire la grandeur du célèbre lac alpin.

www.lmcm.be

Contemporary Collection

The innovative and refined experience of modern architecture.

L'expérience innovante et raffinée de l'architecture moderne.

Copenhagen

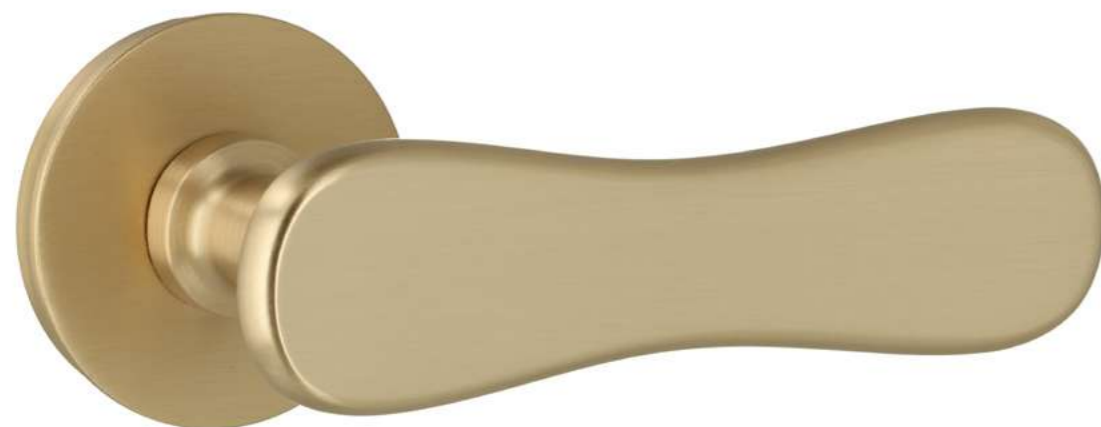

Cannes

Design by Frederik Delbart

The Cannes Collection follows the curves of pebbles while ensuring gentle ergonomics. Smooth and soft edges, an inviting and organic object.

La Collection Cannes épouse les courbes des galets. Elle assure une ergonomie douce. Bords lisses et doux, un objet accueillant et organique.

Material: Brass/Laiton DIN 17166

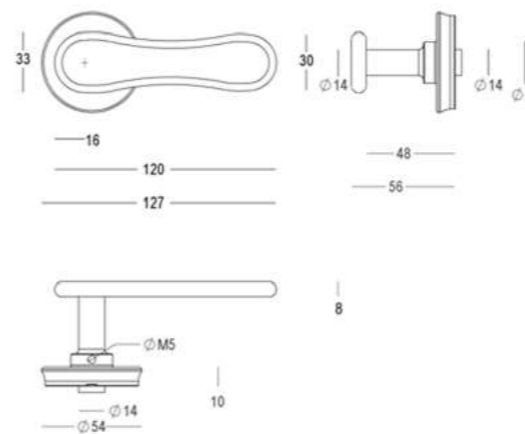

Art. 403-R0



Satin Brass
Laiton Satiné
(22)



Matt Bronze
Bronze Mat
(41)



Dark bronze
Bronze foncé
(42)



Inox Look
Nickel mat satiné
(99)



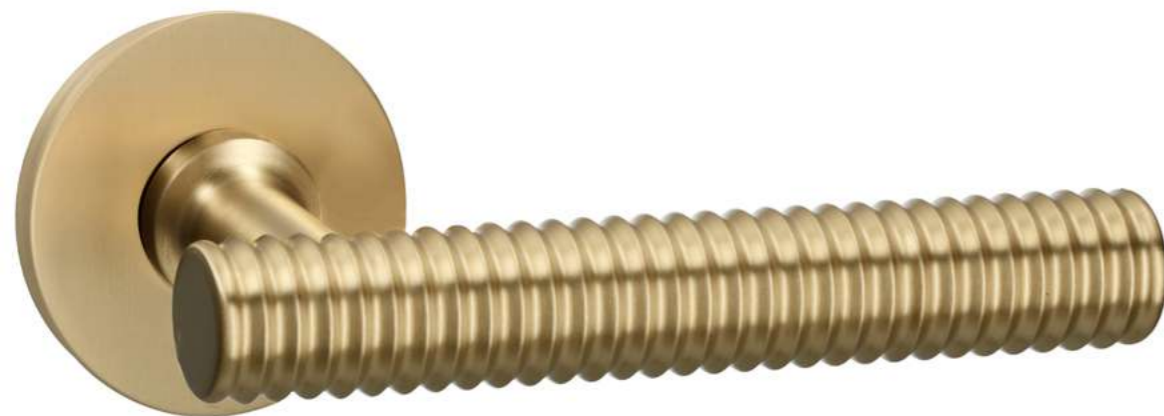

London

Design by Frederik Delbart

As the eponymous city, this vibrant design of contemporary hardware blends a traditional language with a modernistic edge. Based on the visual idea of ripples in the water, the bold yet refined LONDON Collection is as versatile as the city.

En tant que ville éponyme, ce design dynamique de quincaillerie allie la sophistication des techniques de fabrication traditionnelles à une touche moderniste. Basée sur le rythme des ondulations de l'eau, la collection LONDON, audacieuse et raffinée, est aussi polyvalente que la ville.

Material: Brass/Laiton DIN 17166

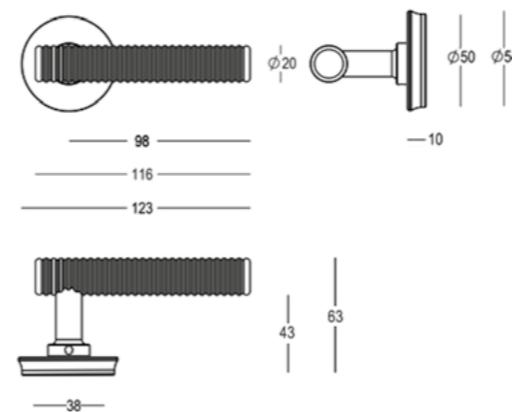

Art. 401-R0



Satin Brass
Laiton Satiné
(22)



Matt Bronze
Bronze Mat
(41)



Dark bronze
Bronze foncé
(42)



Inox Look
Nickel mat satiné
(99)



London



Art. 401-15
Art. 401-KT

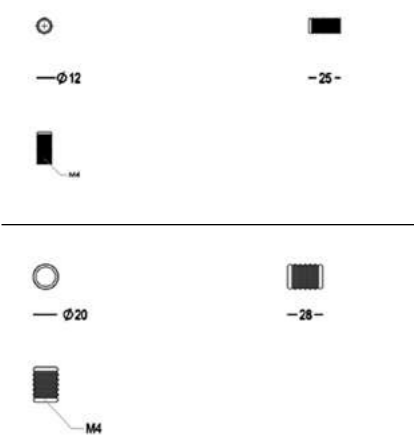

Art. 401-28 (128 mm)
Art. 401-16 (160 mm)

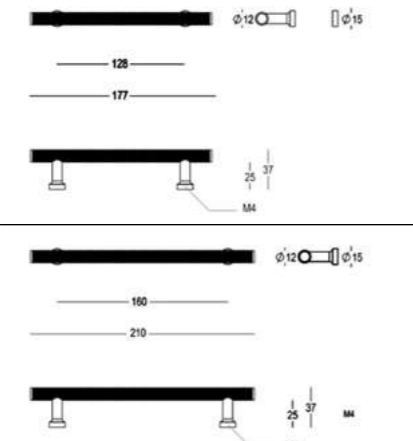

Art. 401-21 (210 mm)
Art. 401-30 (300 mm)

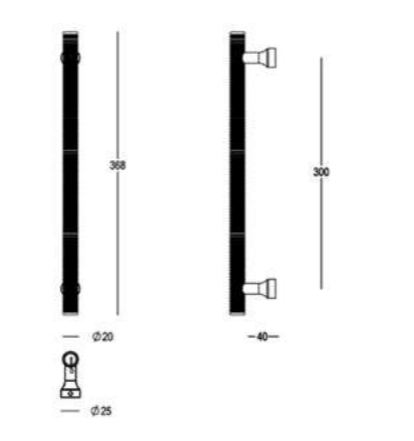

Art. 401-SR

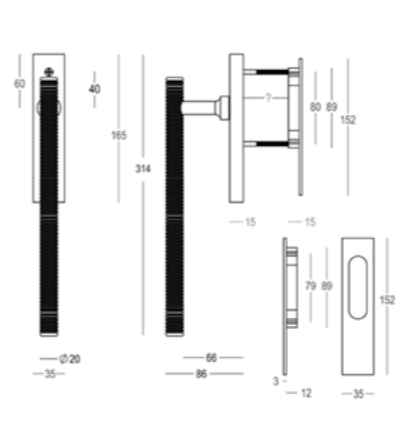

Art. 401-DK (L)
Art. 401-DK (T)

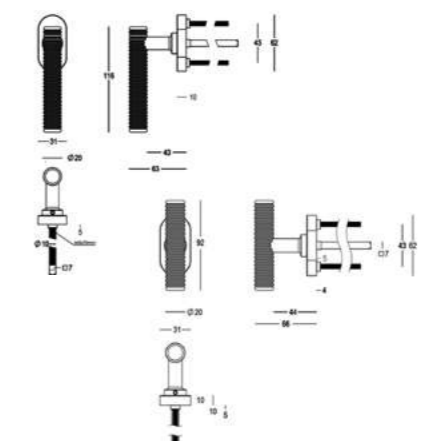

Art. 401-22 (T) Art. 401-RW

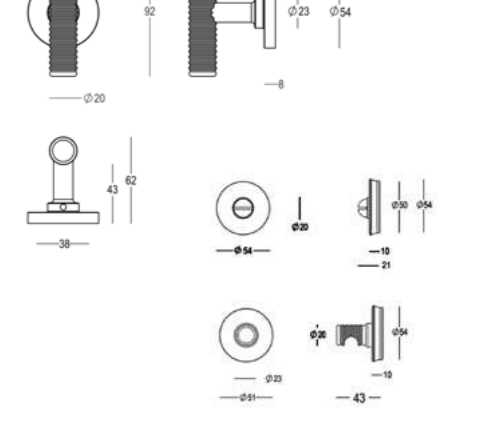



Paris

Design by Frederik Delbart

A soft and smooth curve, finished with strong edges, just like the riverbank of the Seine. The refined PARIS Collection represents timeless elegance with a light and honest design.

Une courbe douce et lisse, terminée par des arêtes fortes, à l'image des berges de la Seine. La collection PARIS dans son design léger et subtil illustre l'élégance intemporelle de la "ville lumière".

Material: Brass/Laiton DIN 17166

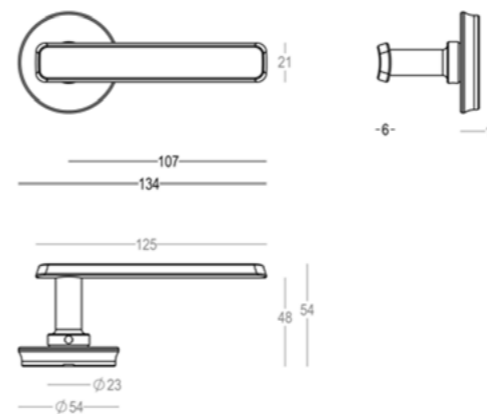

Art. 400-R0



Satin Brass
Laiton Satiné
(22)



Matt Bronze
Bronze Mat
(41)



Dark bronze
Bronze foncé
(42)



Inox Look
Nickel mat satiné
(99)



Paris



Art. 400-KT
Art. 400-MT

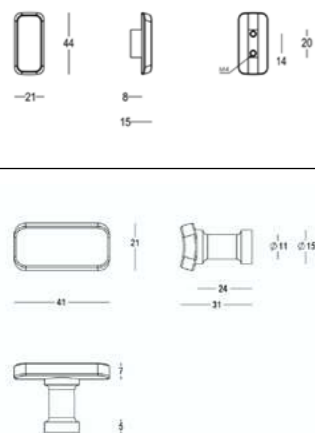

Art. 400-28 (128 mm)
Art. 400-16 (160 mm)

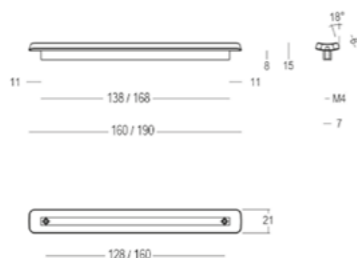

Art. 400-30 (300 mm)

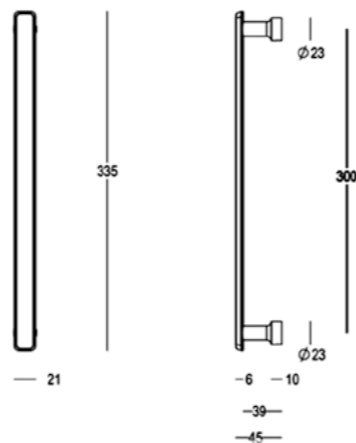

Art. 400-DK (L)
Art. 400-DK (T)

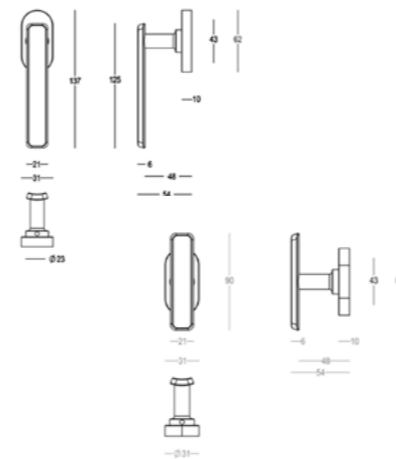

Art. 400-22 (T)

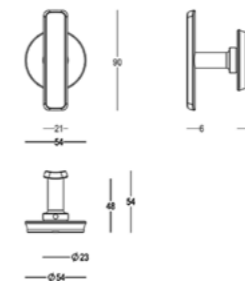

Art. 400-RW

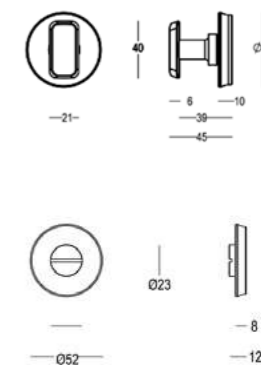



Antwerp

Design by Frederik Delbart

Cutting edge innovation infused by traditional craftsmanship. The refined and elegant ANTWERP Collection looks back to the traditional almond shape door handles, that can only be made by the most experienced of craftsmen.

Une innovation de pointe imprégnée d'un savoir-faire traditionnel. La collection ANTWERP, un retour raffiné et élégant aux poignées de portes traditionnelles de forme ovale. Une fabrication selon les standards des artisans les plus expérimentés.

Material: Brass/Laiton DIN 17166

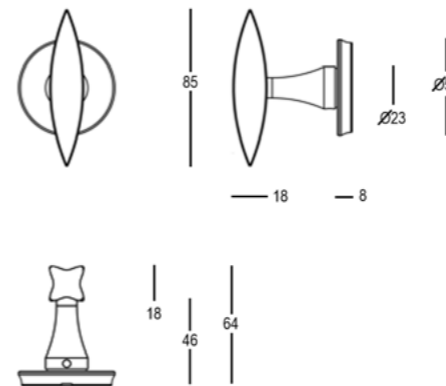

Art. 402-R0



Satin Brass
Laiton Satiné
(22)



Matt Bronze
Bronze Mat
(41)



Dark bronze
Bronze foncé
(42)



Inox Look
Nickel mat satiné
(99)



Antwerp



Art. 402-KT

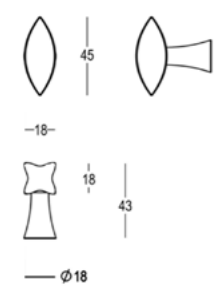

Art. 402-R0-22 (S)
(small 85 mm)

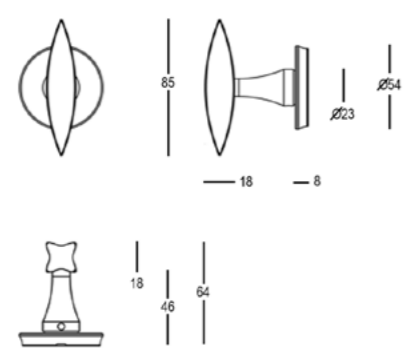

Art. 402-R0-22 (M)
(medium 103 mm)

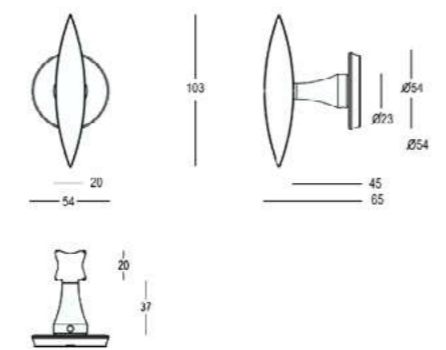

Art. 402-DK-22-11 (S)
(small 85 mm)

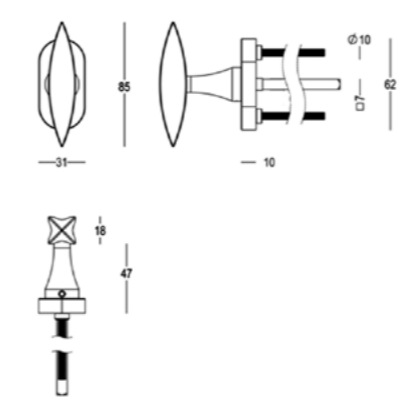

Art. 402-DK-22-11 (M)
(medium 103 mm)

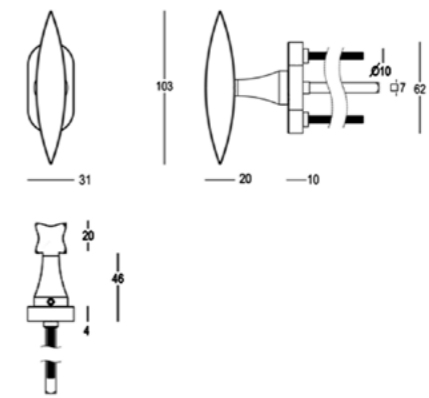



Imperial





Imperial

Design by Frederik Delbart

The Imperial Collection captures the light with its many facets while respecting ergonomics. Uniting the extended know-how of Quincalux with avant-gardist innovative design, the Imperial Collection is crafted in solid brass with extreme precision.

La Collection Imperial capte la lumière avec ses multiples facettes tout en respectant l'ergonomie. Alliant le solide savoir-faire de Quincalux à un design novateur avant-gardiste, la Collection Imperial est réalisée en laiton massif avec une extrême précision.

Material: Brass/Laiton DIN 17166

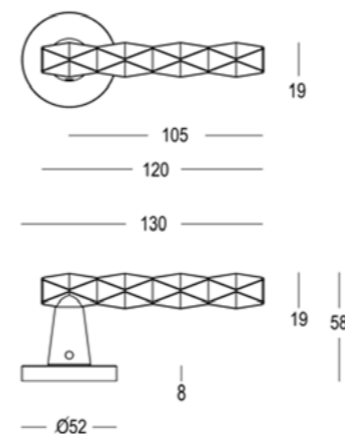

Art. 200-R0



Dark bronze
Bronze foncé
(42)

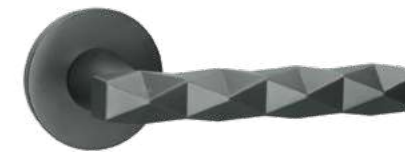

Bright nickel
Nickel brillant
(09)

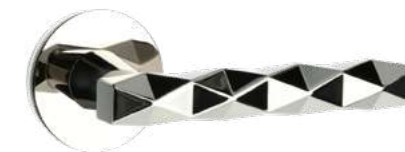

Satin Brass
Laiton Satiné
(22)

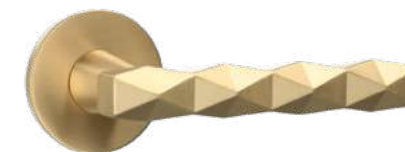

Matt Bronze
Bronze Mat
(41)



Inox Look
Nickel mat satiné
(99)

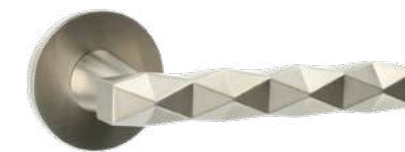

Imperial



Art. 200-KT

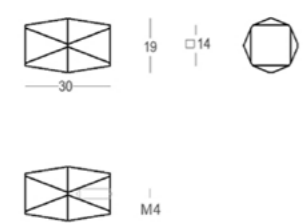

Art. 200-21 (210 mm)

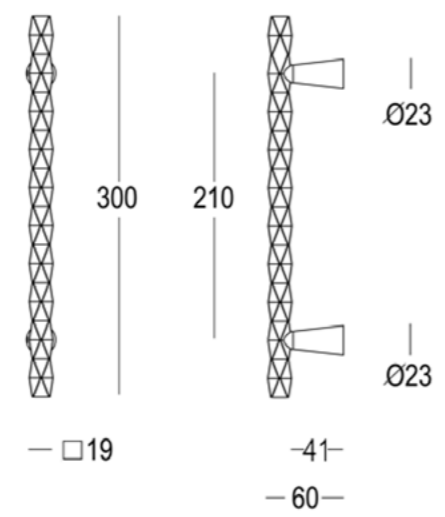

Art. 200-RO (T)

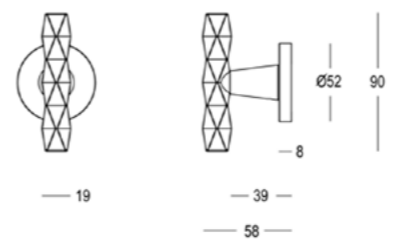

Art. 200-DK (L)

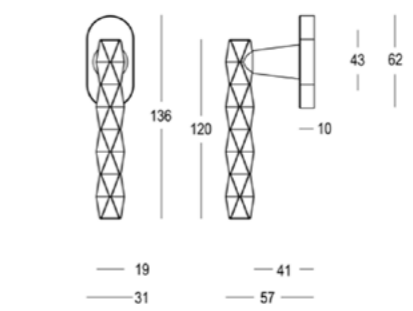

Art. 200-DK (T)

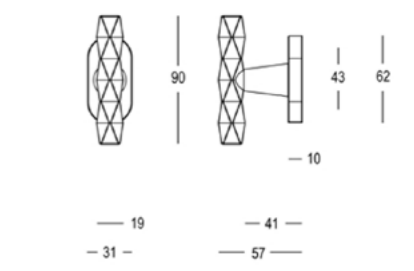



Helsinki



Helsinki

Design by Jeffrey Huyghe

The Helsinki Collection is recognized by simple, flowing lines. The door handle and its base enter into a dialogue, they create one refined, minimalist whole.

La collection Helsinki se distingue par ses lignes simples et fluides. La poignée de porte et sa base entrent en dialogue, créant un ensemble raffiné et minimaliste.

Material: Aluminium EN AW 6060

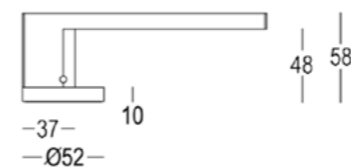
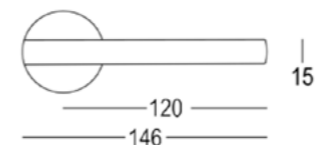

Black textured
Noir mat structuré
(60)



White textured
Blanc mat structuré
(65)



Art. 199-R0



Helsinki



To be specified - À spécifier :

Left
Gauche

Right
Droite

Art. 199-KT

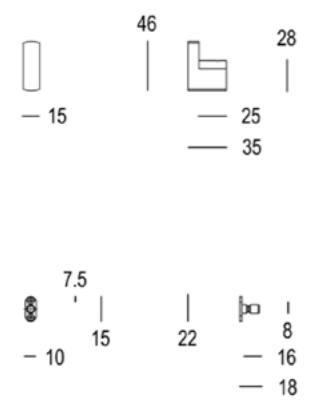

Art. 199-28 (128 mm)
Art. 199-60 (160 mm)

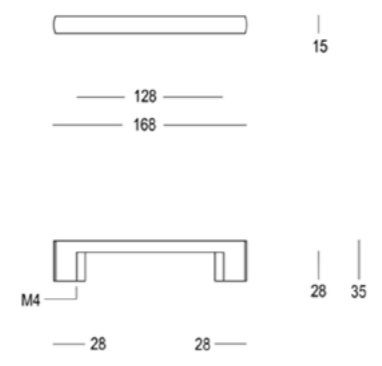

Art. 199-30 (300 mm)

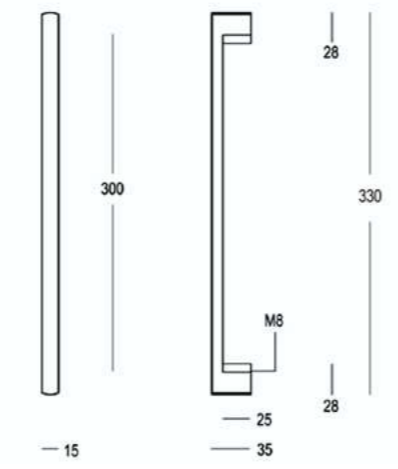

Art. 199-HK

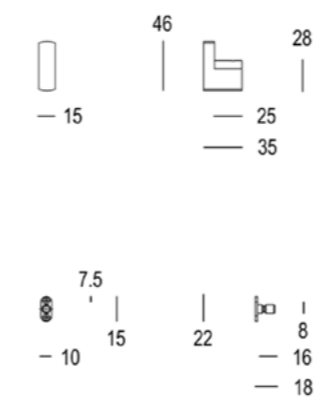

Art. 199-RW (L)
Art. 199-RW (R)

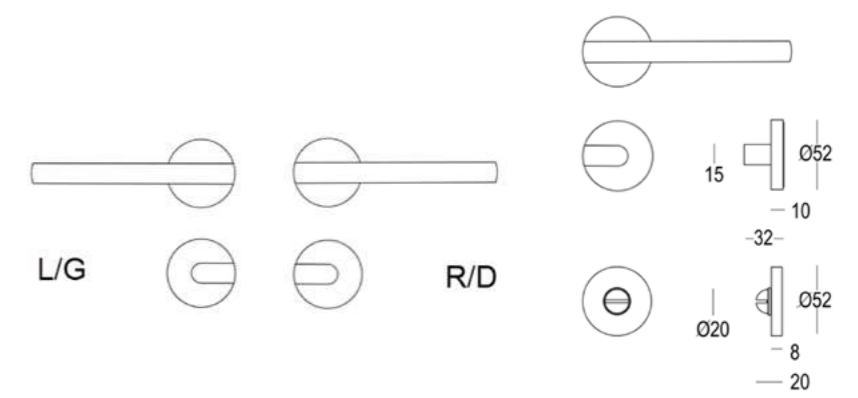



Athena



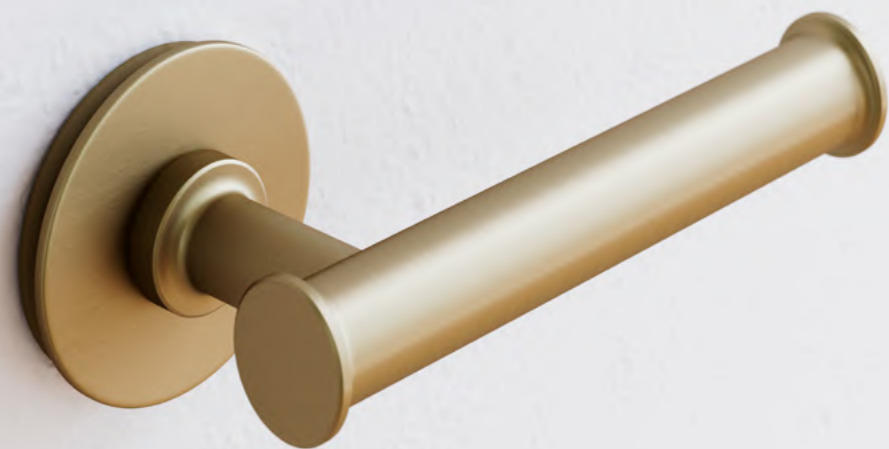

Athena

Design by Frederik Delbart

Inspired by ancient architecture, the Athena Collection brings the greatness of classic monuments in a subtle form.

Inspirée de l'architecture ancienne, la collection Athena apporte la grandeur des monuments classiques sous une forme subtile.

Material: Brass/Laiton DIN 17166

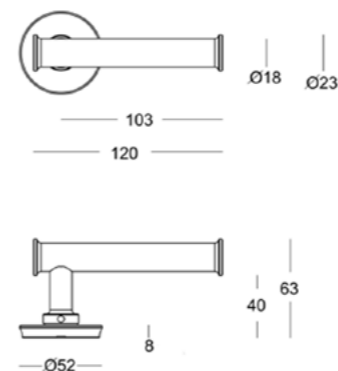

Art. 198-R0



Black textured
Noir mat structuré
(60)



White textured
Blanc mat structuré
(65)

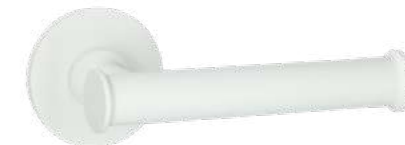

Satin Brass
Laiton Satiné
(22)



Matt Bronze
Bronze Mat
(41)



Inox Look
Nickel mat satiné
(99)



Athena



Art. 198-15
Art. 198-KT

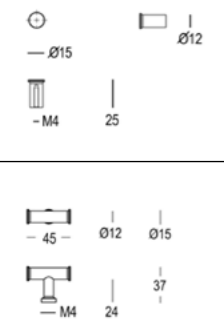

Art. 198-28 (128 mm)
Art. 198-16 (160 mm)

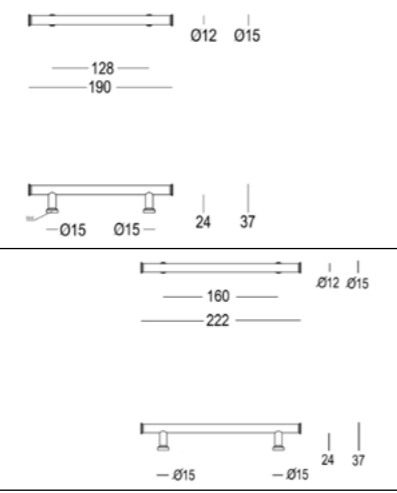

Art. 198-21 (210 mm)
Art. 198-30 (300 mm)

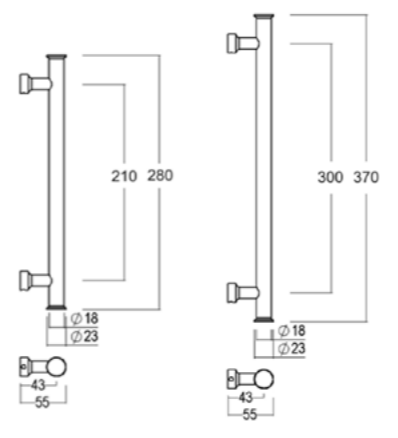

Art. 198-SR

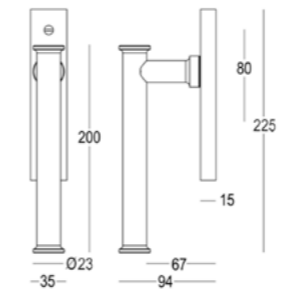

Art. 198-DK (L)
Art. 198-DK (T)

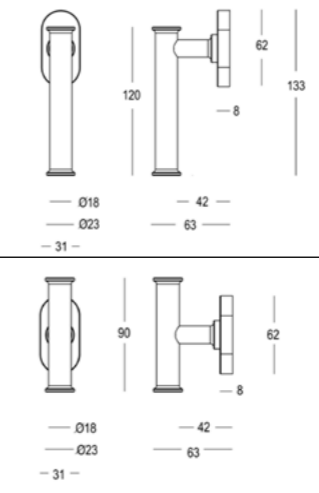

Art. 198-22 (T) Art. 198-RW

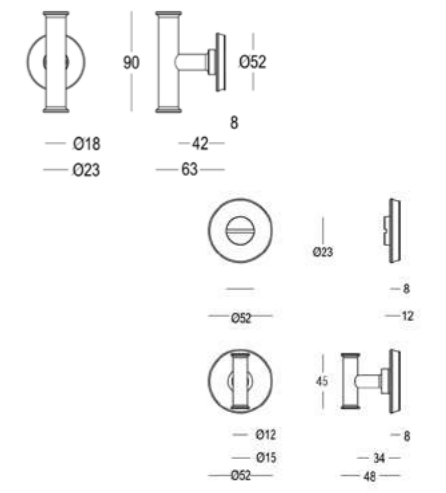



Copenhagen





Copenhagen

Design by Frederik Delbart

The refined Copenhagen Collection is the result of the evolution of traditional crafted hardware into contemporary design.

Merveille de raffinement, la collection Copenhagen est le résultat de l'évolution de la quincaillerie artisanale traditionnelle vers le design contemporain.

Material: Brass/Laiton DIN 17166

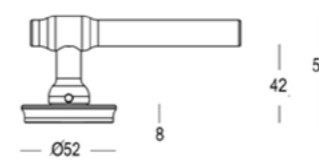
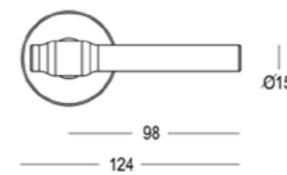

Art. 197-R0



Black textured
Noir mat structuré
(60)



White textured
Blanc mat structuré
(65)



Satin Brass
Laiton Satiné
(22)



Matt Bronze
Bronze Mat
(41)



Inox Look
Nickel mat satiné
(99)



Copenhagen



Art. 197-14
Art. 197-KT

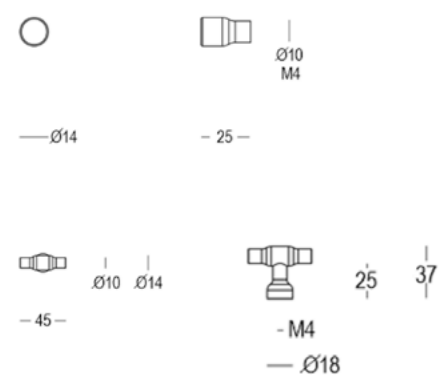

Art. 197-28 (128 mm)
Art. 197-16 (160 mm)

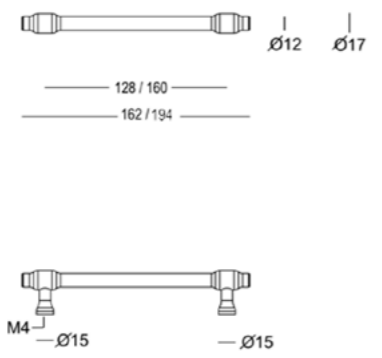

Art. 197-21 (210 mm)
Art. 197-30 (300 mm)

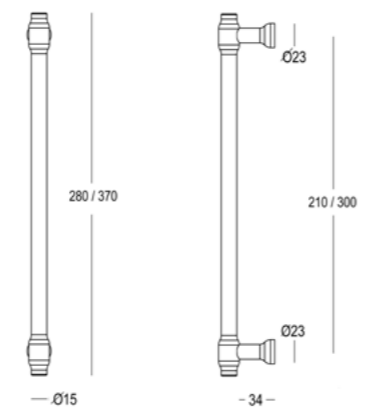

Art. 197-SR

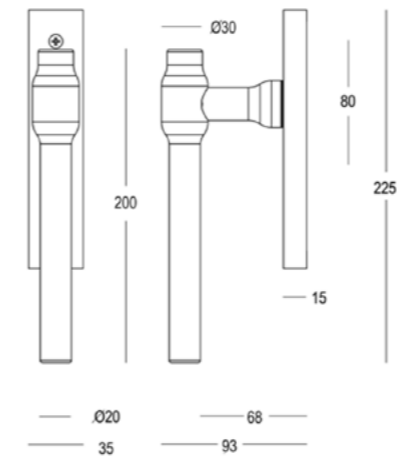

Art. 197-DK (L)
Art. 197-DK (T)

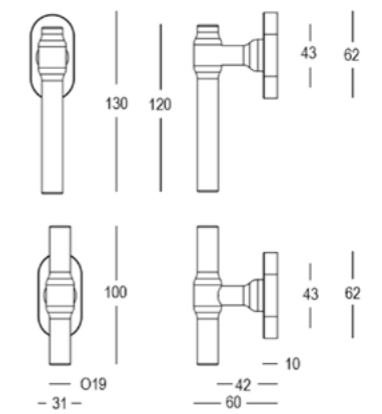

Art. 197-22 (T) Art. 197-RW

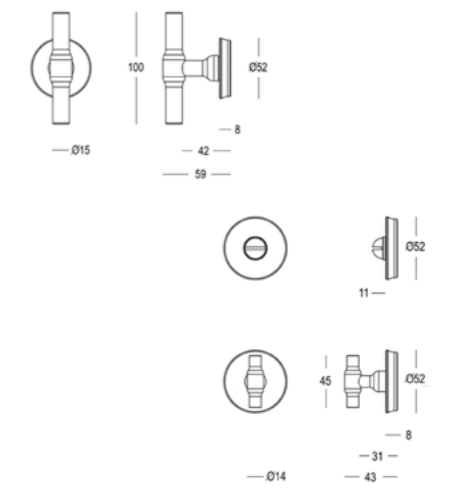



Cassis

Design by Quincalux Design Team

Material: Brass/Laiton DIN 17166



— 052 —

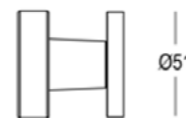

— 8 —
— 36 —
— 51 —

Art. 196-R0



Black textured
Noir mat structuré
(60)



White textured
Blanc mat structuré
(60)



Satin Brass
Laiton Satiné
(22)



Matt Bronze
Bronze Mat
(41)



Inox Look
Nickel mat satiné
(99)





Monaco

Design by Quincalux Design Team

Material: Brass/Laiton DIN 17166

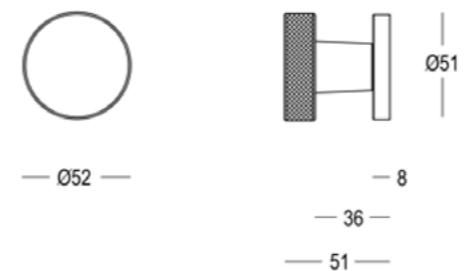

Art. 195-R0



Dark bronze
Bronze foncé
(42)



Satin Brass
Laiton Satiné
(22)



Matt Bronze
Bronze Mat
(41)



Inox Look
Nickel mat satiné
(99)





Como



Como

Design by Lieven Musschoot & Cas Moor

In the same way that Lake Como creates a Y-silhouette in the mountains, the 'Como collection', is cut out in noble brass.

Tout comme le lac de Come qui crée une silhouette en forme d'Y dans les montagnes, la collection 'Como', dessinée par Cas Moor et Lieven Musschoot, est découpée dans du laiton massif.

Material: Brass/Laiton DIN 17166

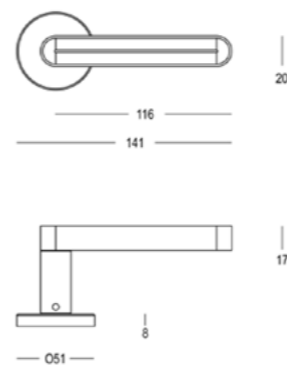

Art. 194-R0



Dark Bronze
Bronze foncé
(42)



White textured
Blanc mat structuré
(65)



Satin Brass
Laiton Satiné
(22)



Matt Bronze
Bronze Mat
(41)



Inox Look
Nickel mat satiné
(99)



Como

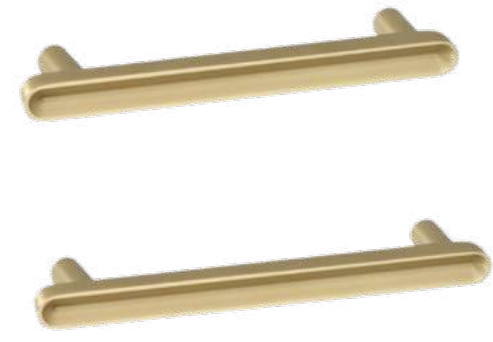

Art. 194-15
Art. 194-20
Art. 194-KT

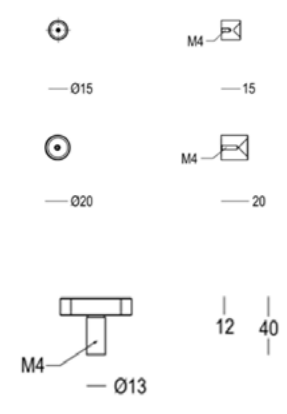

Art. 194-28 (128 mm)
Art. 194-16 (160 mm)

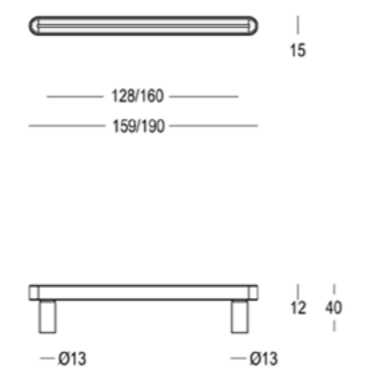

Art. 194-21 (210 mm)
Art. 194-30 (300 mm)

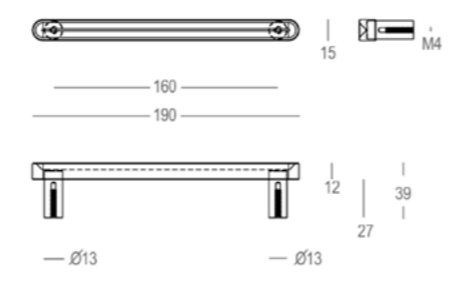

Art. 194-SR

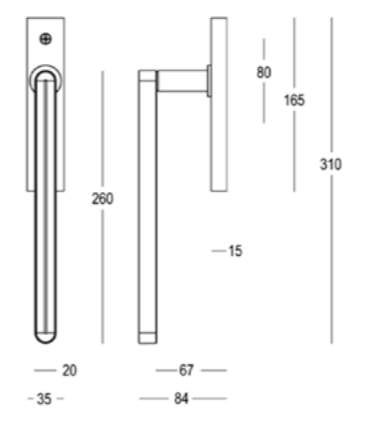

Art. 194-DK (L)
Art. 194-DK (T)

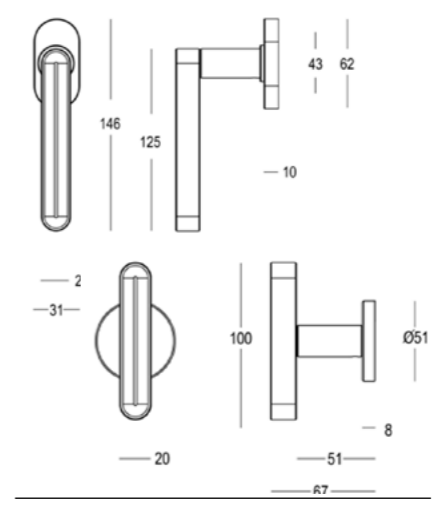

Art. 194-RO (T)

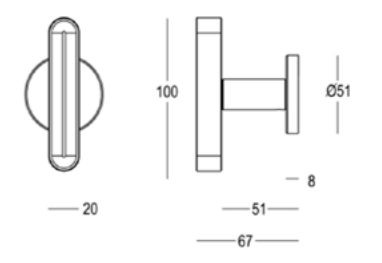



Palma



Palma

Design by Julien Renault

The Palma Collection gives life to a standard profile reworked into a neat and delicate format. A utilitarian piece of metal with a rhombus profile, the simple grip provides a vast potential.

La collection Palma donne vie à un profil standard retravaillé dans un format soigné et délicat. Une pièce de métal utilitaire avec un profil en losange, la prise simple offre un vaste potentiel.

Material: Brass/Laiton DIN 17166

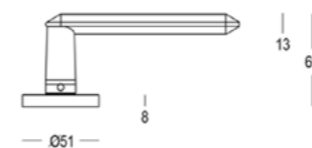
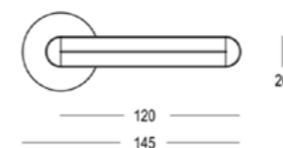

Art. 193-R0



Black textured
Noir mat structuré
(60)



White textured
Blanc mat structuré
(65)



Satin Brass
Laiton Satiné
(22)



Matt Bronze
Bronze Mat
(41)



Inox Look
Nickel mat satiné
(99)



Palma



Art. 193-KT

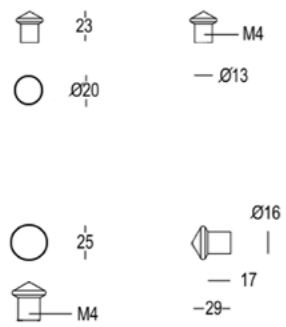

Art. 193-28 (128mm)
Art. 193-16 (160mm)

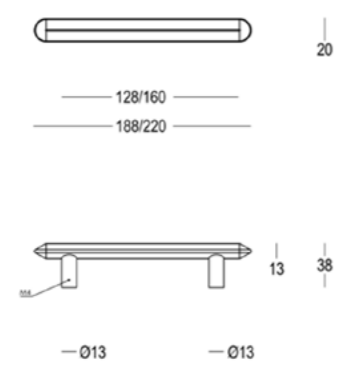

Art. 193-21 (210mm)
Art. 193-30 (300mm)

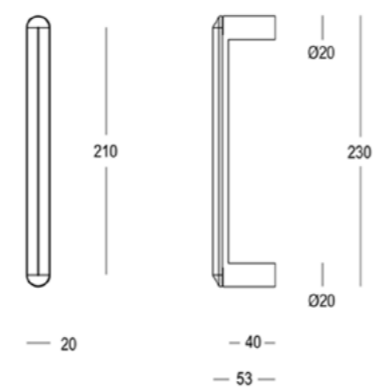

Art. 193-DK (L)

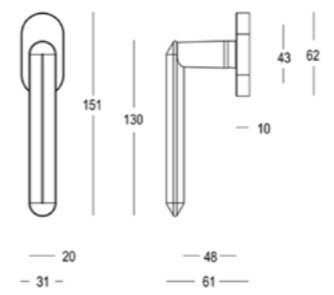

Art. 193-DK (T)

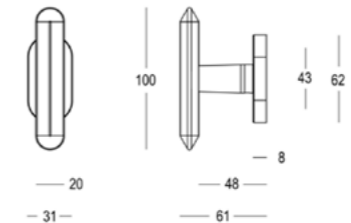

Art. 193-RO (T)

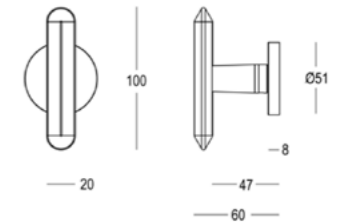



Oslo

Design by Frederik Delbart

For the Oslo Collection, the designer Frederik Delbart found inspiration in the minimalistic nordic aesthetic, which qualities are emphasised in durable, functional, simple and natural forms.

Pour la collection Oslo, le designer Frederik Delbart s'est inspiré de l'esthétique nordique minimaliste, dont les qualités sont mises en valeur dans des formes durables, fonctionnelles, simples et naturelles.

Material: Brass/Laiton DIN 17166

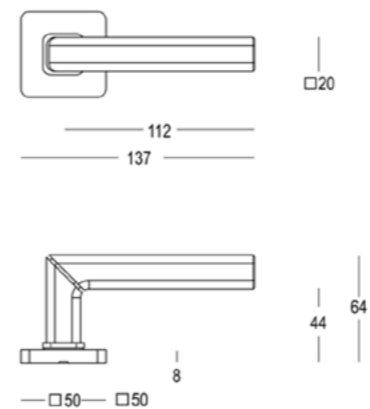

Art. 192-R0



Black textured
Noir mat structuré
(60)



White textured
Blanc mat structuré
(65)



Satin Brass
Laiton Satiné
(22)



Matt Bronze
Bronze Mat
(41)



Inox Look
Nickel mat satiné
(99)



Oslo

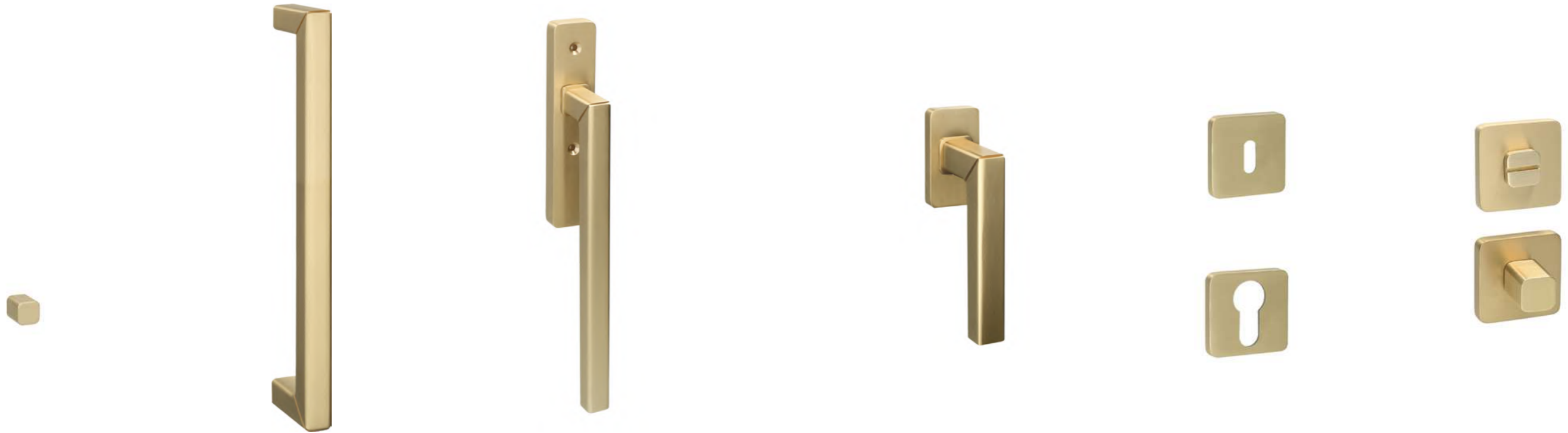

Art. 192-20

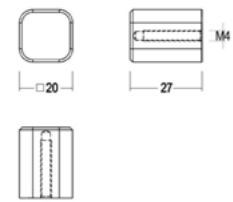

Art. 192-21 (210 mm)
Art. 192-30 (300 mm)

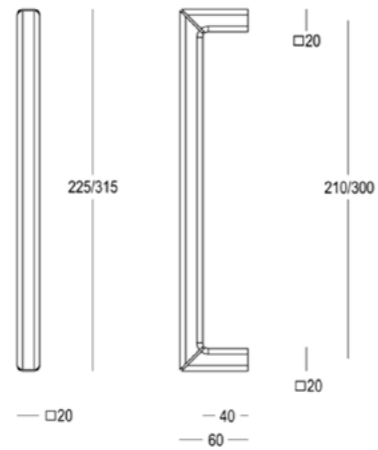

Art. 192-SR

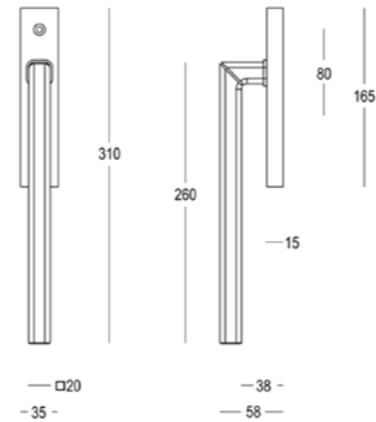

Art. 192-DK

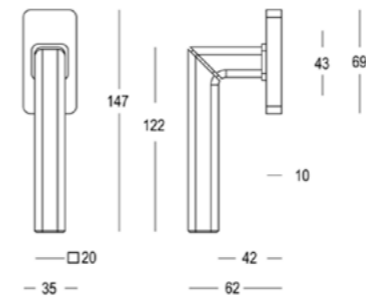

Art. 192-0E
Art. 192-0C

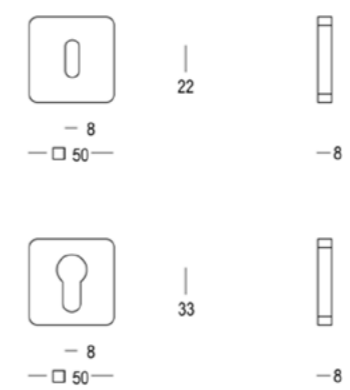

Art. 192-RW

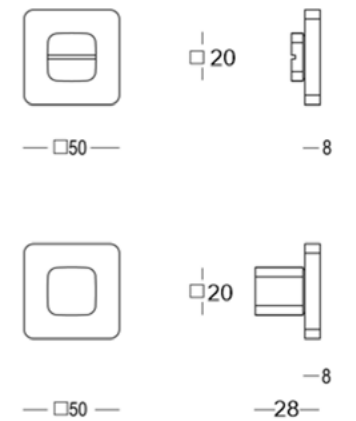



Lausanne

Design by Quincalux Design Team

Lausanne, located on the Lac Léman, is well-known for not a its beautiful scenery, but as well as focus of international sport, hosting the International Olympic Committee.

Lausanne, située au bord du lac Léman, est réputée non seulement pour la beauté de ses paysages, mais aussi parce qu'elle se trouve au coeur des sports internationaux et accueille le Comité International Olympique.

Material: Brass/Laiton DIN 17166

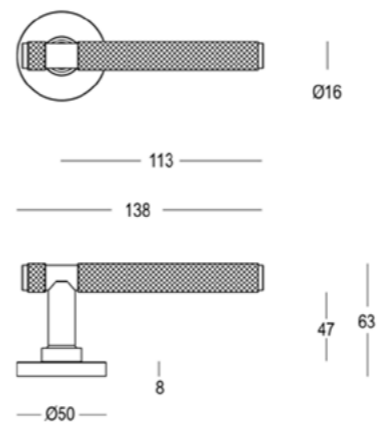

Art. 191-R0



Dark Bronze
Bronze Foncé
(42)



Satin Brass
Laiton Satiné
(22)



Matt Bronze
Bronze Mat
(41)



Inox Look
Nickel mat satiné
(99)





Montreux

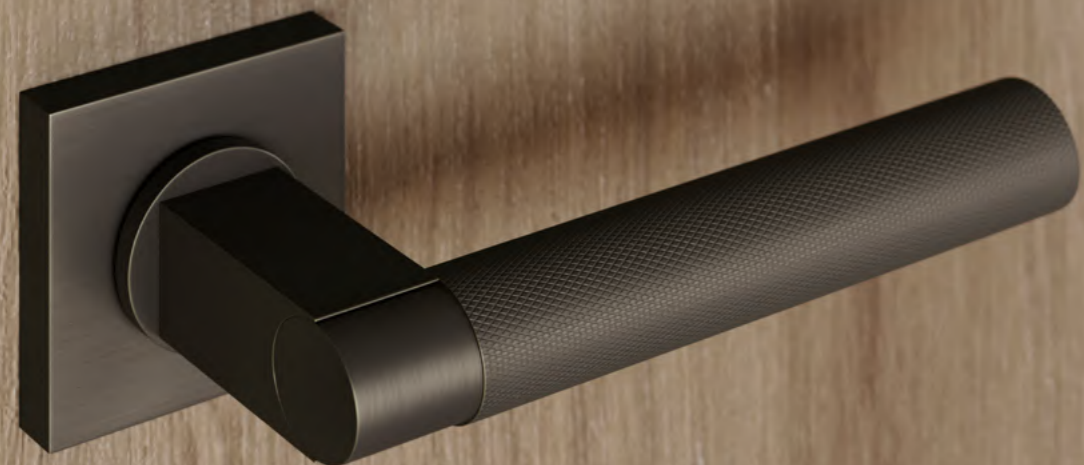

Montreux

Design by Quincalux Design Team

Montreux, located on the Lac Léman in Switzerland, is the doorway to the Swiss Mountain-region. Numerous mountain-chains, running rivers as well as the Lac Léman carve into the landscape. Quincalux designed a new collection, where new tools are cutting into brass, creating knurled patterns.

Montreux, située au bord du lac Léman en Suisse, est la porte d'entrée de la région de montagne Suisse.

De nombreuses chaînes de montagnes, des rivières courantes ainsi que le lac Léman taillent le paysage.

Quincalux a conçu une nouvelle collection, dans laquelle de nouveaux outils coupent le laiton et créent des motifs guillochés.

Material: Brass/Laiton DIN 17166

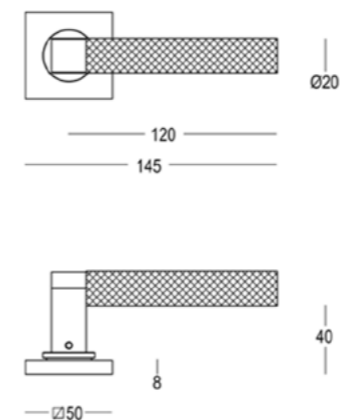

Art. 190-R0



Dark Bronze
Bronze Foncé
(42)



Satin Brass
Laiton Satiné
(22)



Matt Bronze
Bronze Mat
(41)



Inox Look
Nickel mat satiné
(99)



Montreux



Art. 190-20

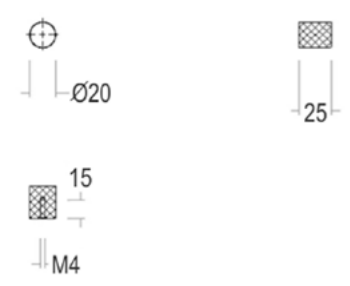

Art. 190-28 (128 mm)
Art. 190-16 (160 mm)

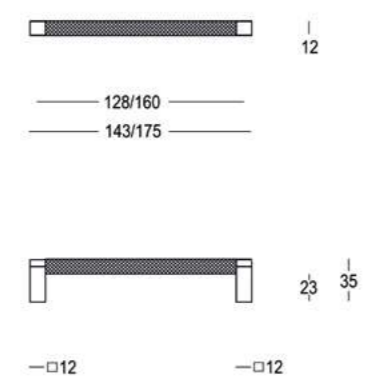

Art. 190-21 (210 mm)
Art. 190-30 (300 mm)

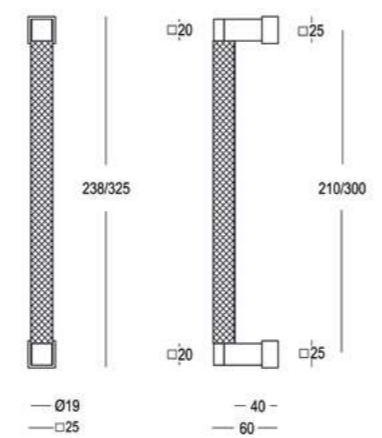

Art. 190-SR

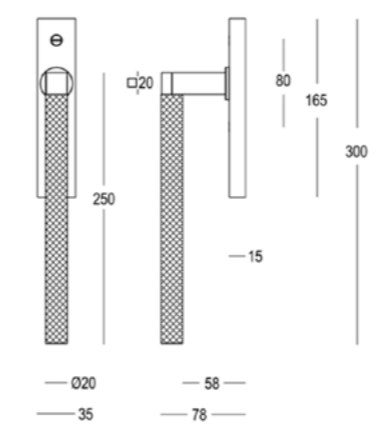

Art. 190-DK

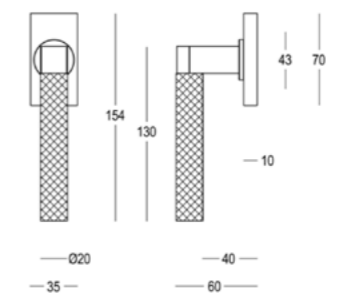

Art. 190-RW

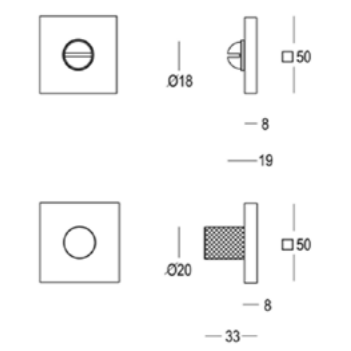



Royal





Royal

Design by Frederik Delbart

The Royal Collection lets classicism and modernity collide, drawing the eye through the gentle grooves, as the monolithic design takes its inspiration from the traditional columns of Ancient Rome.

Collection Royal fusionne le classicisme et de la modernité, en attirant le regard à travers des douces rainures, tandis que le design monolithique s'inspire des colonnes traditionnelles de la Rome antique.

Material: Brass/Laiton DIN 17166

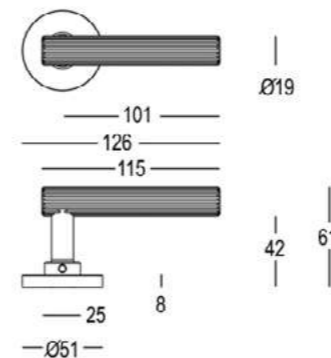

Art. 167-R0



Dark Bronze
Bronze Foncé
(42)



White textured
Blanc mat structuré
(65)



Satin Brass
Laiton Satiné
(22)

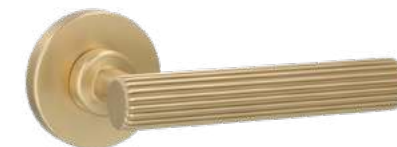

Matt Bronze
Bronze Mat
(41)



Inox Look
Nickel mat satiné
(99)



Royal

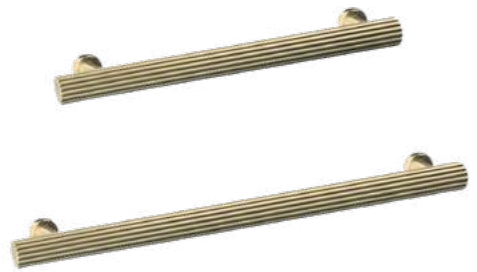

Art. 167-12 (d/12 mm)
Art. 167-20 (d/20 mm)

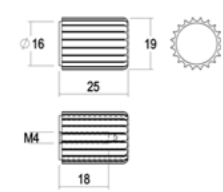
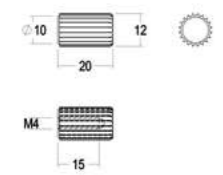

Art. 167-96 (96 mm)
Art. 167-128 (128 mm)

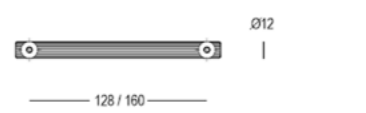
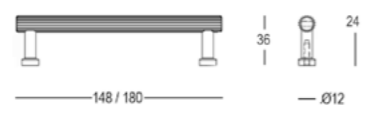

Art. 167-21 (210 mm)
Art. 167-30 (300 mm)

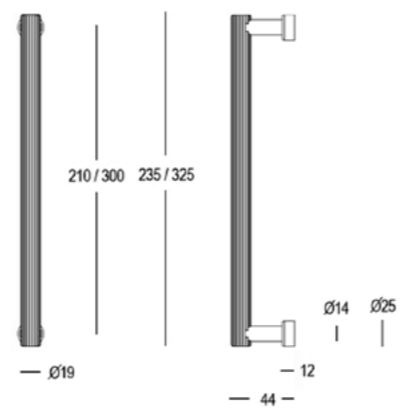

Art. 167-SR

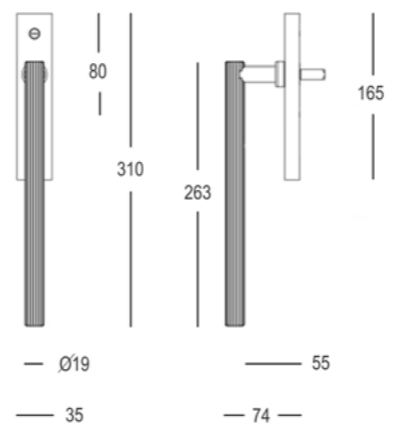

Art. 167-DK (L)
Art. 167-DK (T)

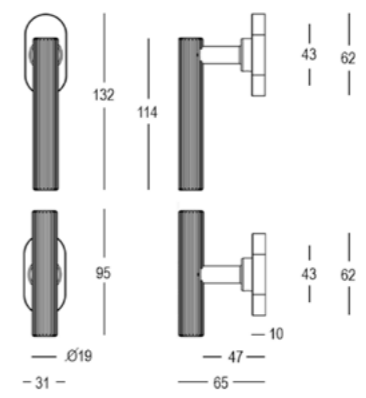

Art. 167-RW

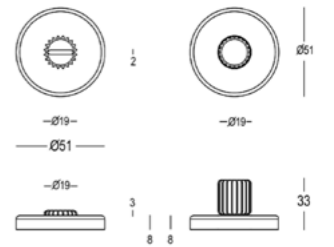



Stockholm

Design by Quincalux Design Team

Elegant and classy collection, matching contemporary as well as classic interiors.

Une collection élégante et raffinée, adaptée aux intérieurs contemporains ou classiques.

Material: Brass/Laiton DIN 17166

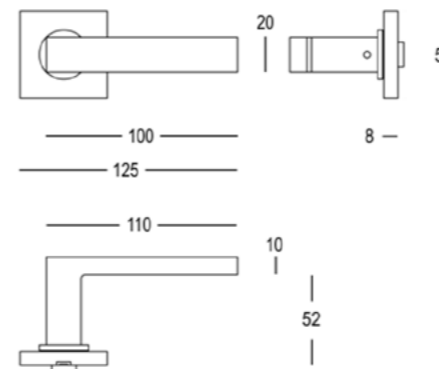

Art. 159-R0



Dark Bronze
Bronze Foncé
(42)



White textured
Blanc mat structuré
(65)



Satin Brass
Laiton Satiné
(22)



Matt Bronze
Bronze Mat
(41)



Inox Look
Nickel mat satiné
(99)



Stockholm



Art. 159-20

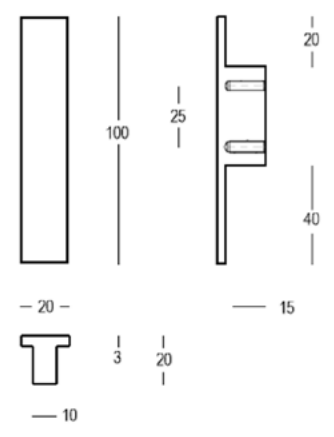

Art. 159-25

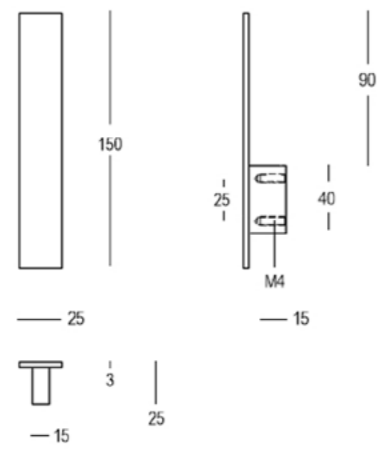

Art. 159-21

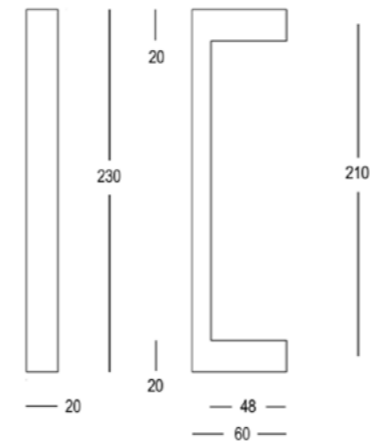

Art. 159-SR

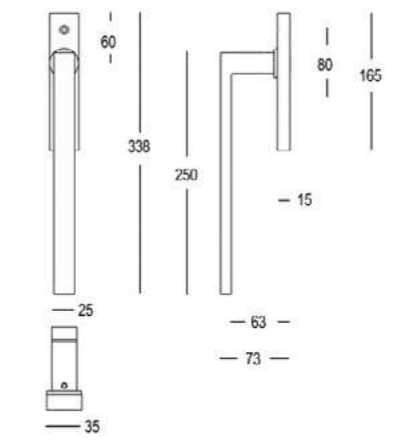

Art. 159-DK (L)

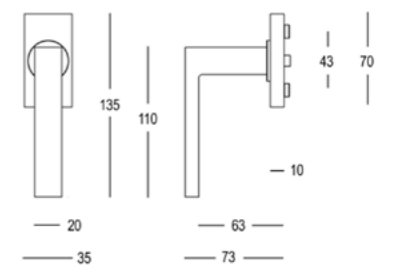



Luxembourg

Design by Quincalux Design Team

Beautiful collection marked by its straight and linear lines.

Une splendide collection marquée par ses lignes droites et linéaires.

Material: Brass/Laiton DIN 17166

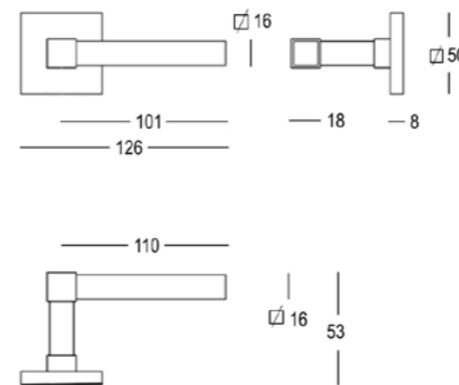

Art. 158-R0



Black textured
Noir mat structuré
(60) (ALU)



White textured
Blanc mat structuré
(65) (ALU)



Satin Brass
Laiton Satiné
(22)



Matt Bronze
Bronze Mat
(41)



Inox Look
Nickel mat satiné
(99)



Luxembourg



Art. 158-50

Art. 158-35

Art. 158-25

Art. 158-30

Art. 158-SR

Art. 158-DK (L)

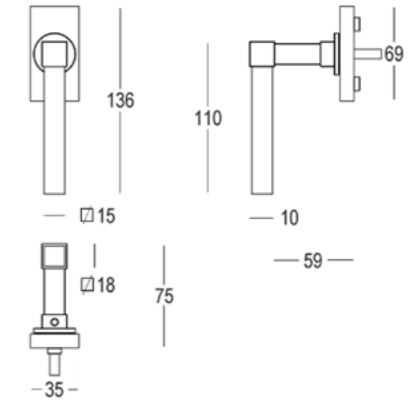
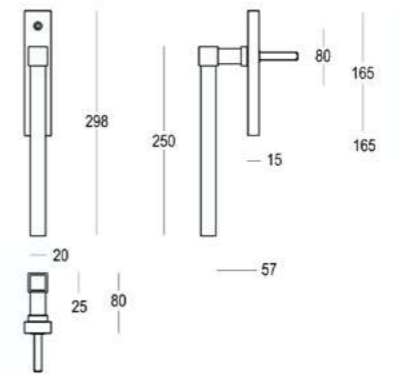
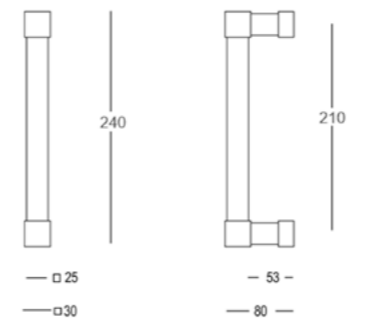
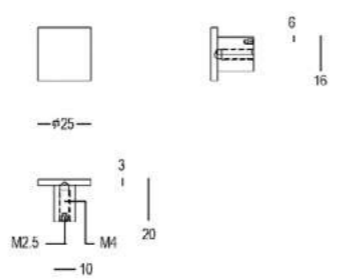
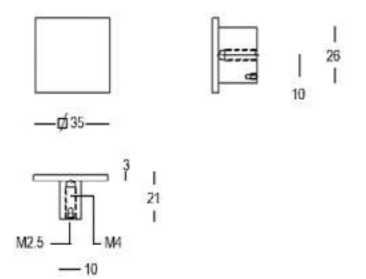
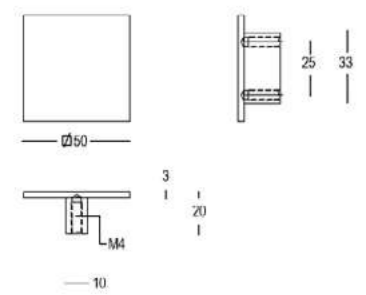

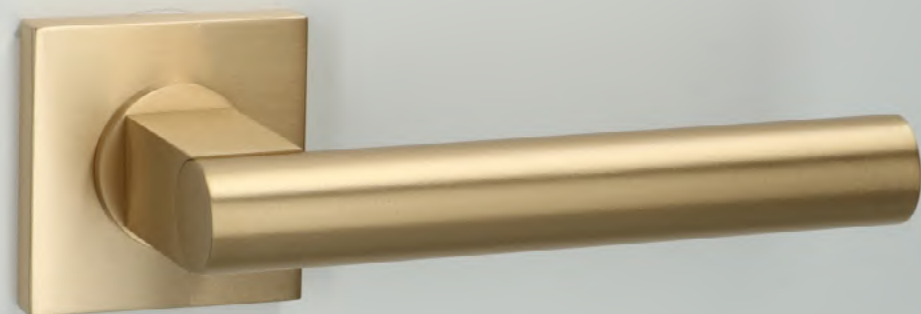

Berlin

Design by Quincalux Design Team

Berlin is a city of architectural contrasts, where historical buildings stand alongside modern architecture as the past and present intermingle. The Berlin collection by Quincalux is marked by square forms combined with round, circular handle part.

La ville de Berlin se distingue par ses contrastes architecturaux. Les bâtiments historiques y côtoient une architecture moderne où se confondent passé et présent. La collection Berlin de Quincalux affiche des formes carrées alliées à un élément rond et circulaire.

Material: Brass/Laiton DIN 17166

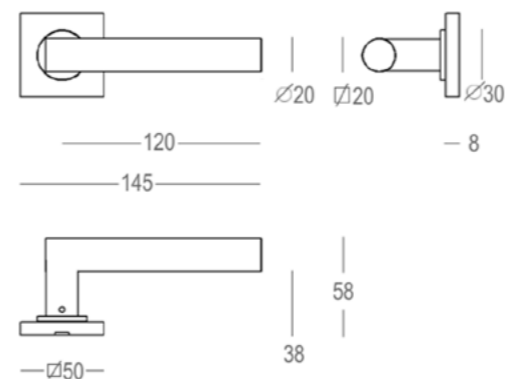

Art. 157-R0



Black textured
Noir mat structuré
(60) (ALU)



White textured
Blanc mat structuré
(65) (ALU)

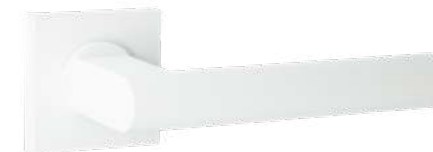

Satin Brass
Laiton Satiné
(22)



Matt Bronze
Bronze Mat
(41)



Inox Look
Nickel mat satiné
(99)



Berlin



Art. 157-21 (210mm)

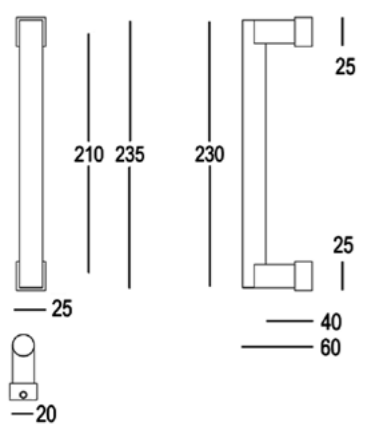

Art. 157-SR

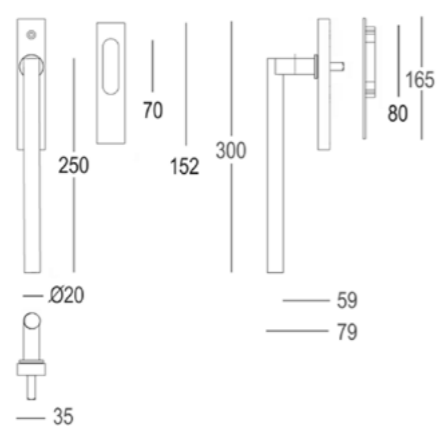

Art. 157-DK

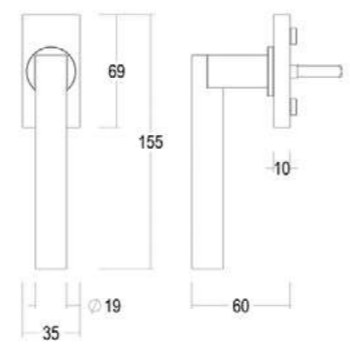

Photographe: Didier Delmas
 Hôtel Les Roches Blanches (5*), Cassis (F)
 Agence Kappel Architectes





Luxor

Design by Quincalux Design Team

The name of this handle clearly refers to a typical Egyptian structure; the seizable part of the handle having a pyramidal shape.

Le nom de cette poignée fait clairement référence à une structure typiquement égyptienne, avec sa prise de main de forme pyramidale.

Material: Brass/Laiton DIN 17166

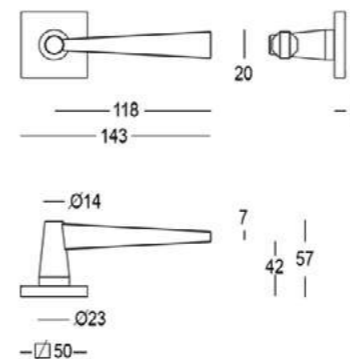

Art. 156-R0



Black textured
Noir mat structuré
(60)



White textured
Blanc mat structuré
(65)



Satin Brass
Laiton Satiné
(22)



Matt Bronze
Bronze Mat
(41)



Inox Look
Nickel mat satiné
(99)





Lisbon

Design by Quincalux Design Team

Starting with a round rose, followed by a smoothly bended rounded off handle.
Resulting in an elegant and ergonomic handle.

Commençant par une rose ronde, suivie d'une poignée arrondie et délicatement courbée, elle donne vie à une élégante poignée ergonomique.

Material: Brass/Laiton DIN 17166

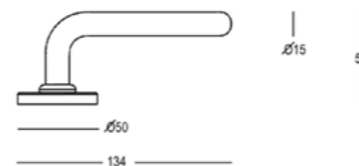

Art. 153-R0



Black textured
Noir mat structuré
(60)



White textured
Blanc mat structuré
(65)



Satin Brass
Laiton Satiné
(22)



Matt Bronze
Bronze Mat
(41)



Inox Look
Nickel mat satiné
(99)





Madrid

Design by Quincalux Design Team

The Madrid handle is marked by a timeless and practical beauty of a kind...

La poignée Madrid respire la beauté intemporelle et pratique...

Material: Brass/Laiton DIN 17166

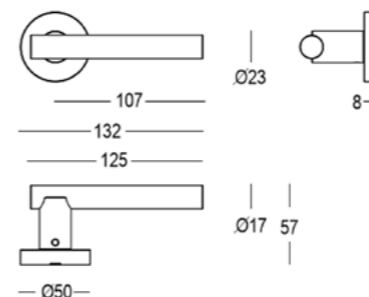

Art. 152-R0



Black textured
Noir mat structuré
(60)



Satin Brass
Laiton Satiné
(22)



Matt Bronze
Bronze Mat
(41)



Inox Look
Nickel mat satiné
(99)





Hotel Le Sanglier des Ardennes, Durbuy (B)
Photography: Oriana Gomez-Zerpa



Brussels

Design by Quincalux Design Team

The '124' collection was created by Quincalux in 1965, 130 years after the inauguration of the first European railway between Brussels and Mechelen. The inspiration came from the hardware designed for the interiors of the famous Orient Express, produced by the Belgian company CIWL.

La collection « 124 » a été créée par Quincalux en 1965, 130 ans après l'inauguration du premier chemin de fer continentale, entre Bruxelles et Malines. Toutefois, elle puise son inspiration de la quincaillerie conçue pour le célèbre Orient Express, produite par la société belge CIWL.

Material: Brass/Laiton DIN 17166

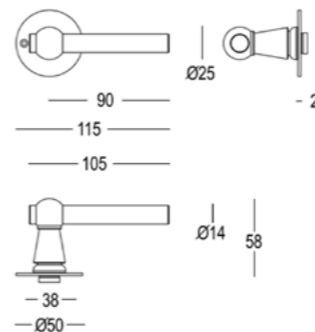

Art. 124-L0



Black textured
Noir mat structuré
(60)



White textured
Blanc mat structuré
(65)



Satin Brass
Laiton Satiné
(22)



Matt Bronze
Bronze Mat
(41)



Inox Look
Nickel mat satiné
(99)



Brussels

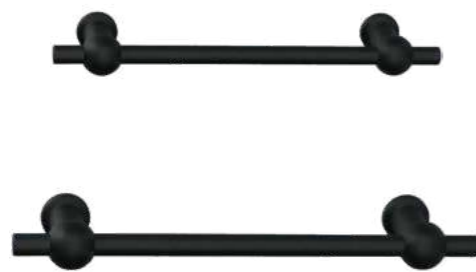

Art. 124-KT

Art. 124-96 (96 mm)
Art. 124-28 (128 mm)

Art. 124-DS

Art. 124-SR

Art. 124-DK (L)
Art. 124-DK (T)

Art. 124-RW

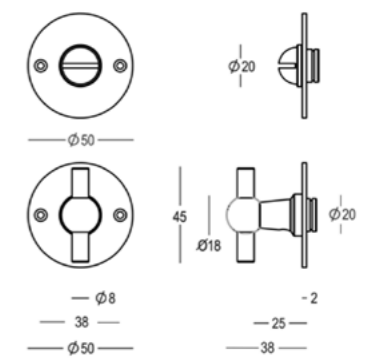
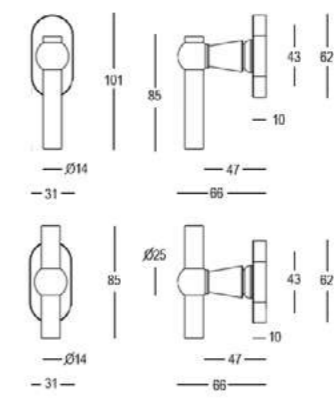
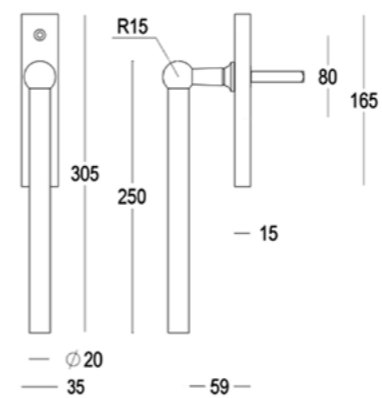
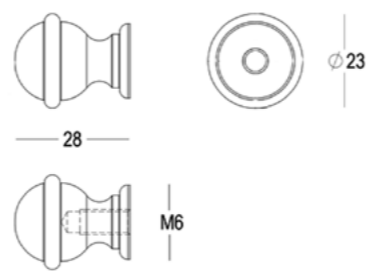
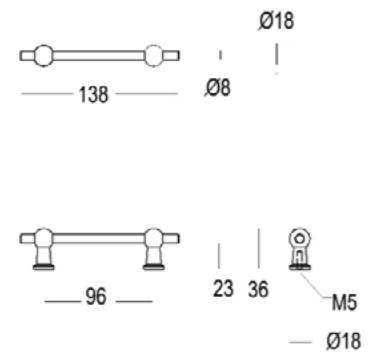
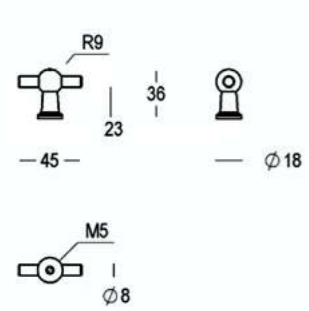
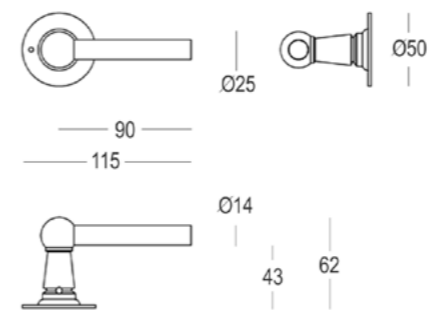



Photo: Steelit

Material: Brass/Laiton DIN 17166



Art. 127-R0

Material: Brass/Laiton DIN 17166

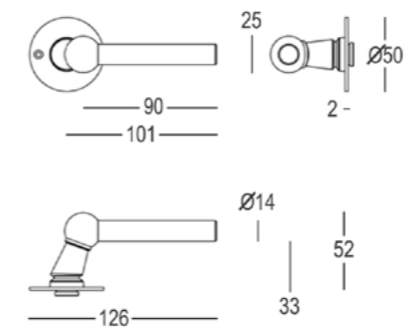

Art. 127-D0

Q-line



Material: Aluminium EN.AW.6060

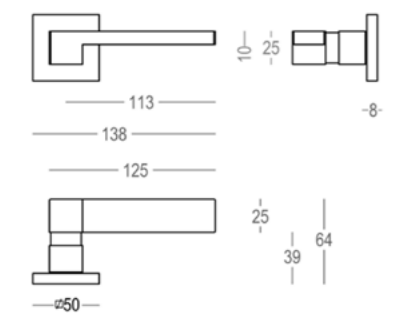

Black textured
Noir mat structuré
(60)



White textured
Blanc mat structuré
(65)



Smoke
(50)



Q-line



Material: Aluminium EN.AW.6060

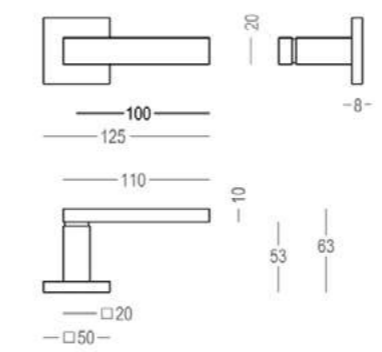

Black textured
Noir mat structuré
(60)



White textured
Blanc mat structuré
(65)



Smoke
(50)



Q-line



Material: Aluminium EN.AW.6060

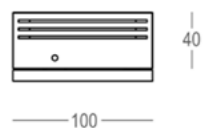
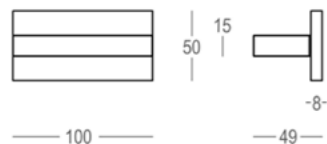

Black textured
Noir mat structuré
(60)



White textured
Blanc mat structuré
(65)



Smoke
(50)



Art. 703-R0



Q-line



Material: Aluminium EN.AW.6060

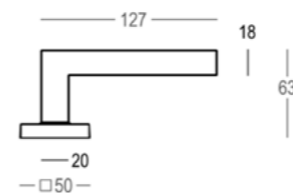
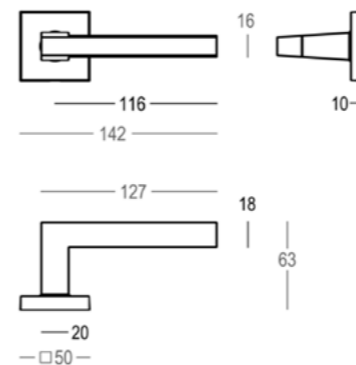

Black textured
Noir mat structuré
(60)



White textured
Blanc mat structuré
(65)



Art. 704-R0



Art. 138-25

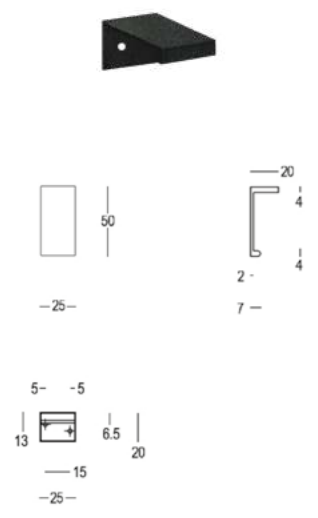

Art. 138-50

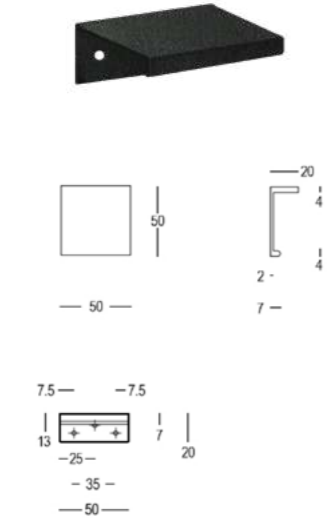

Art. 138-75

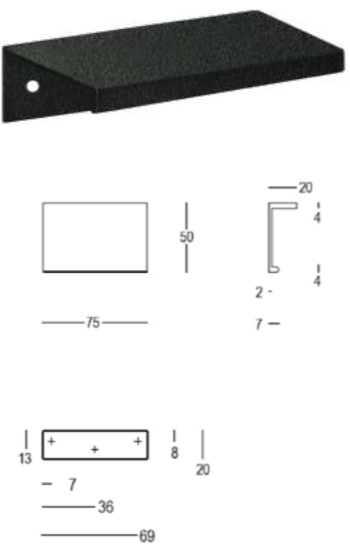

Art. 159-20

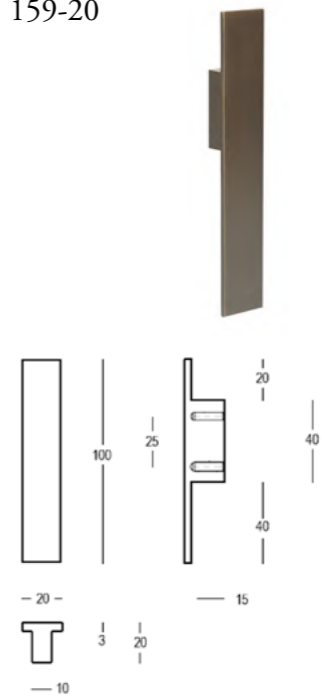

Art. 159-25

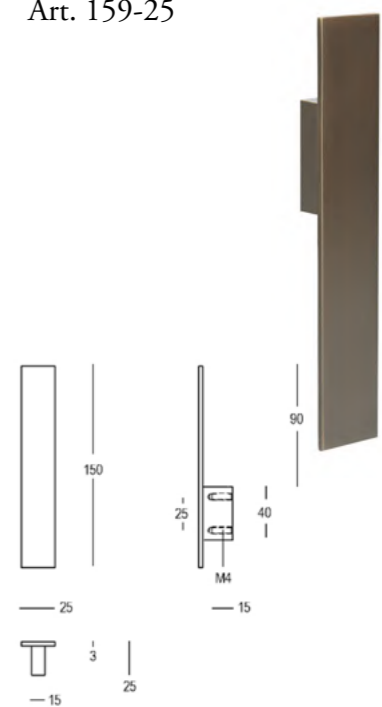

Art. 139-50

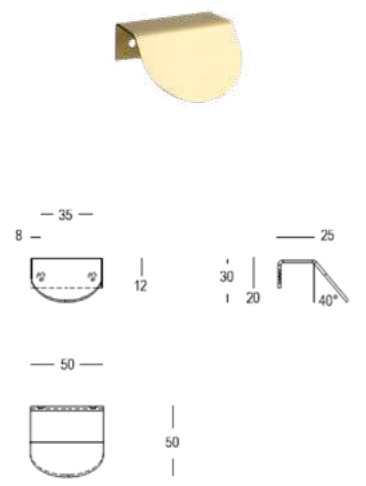

Art. 139-75

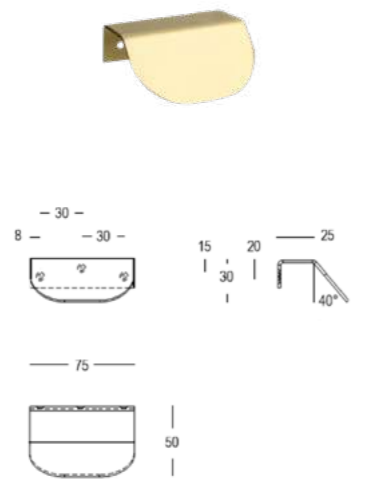

Art. 139-15

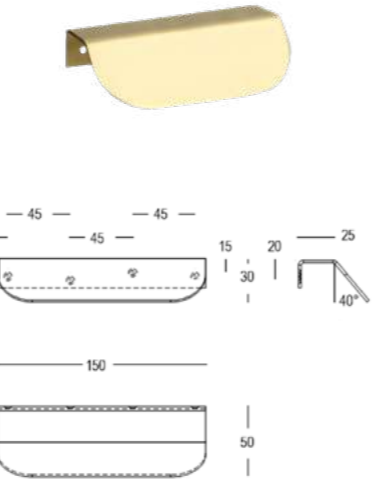

Art. 158-25

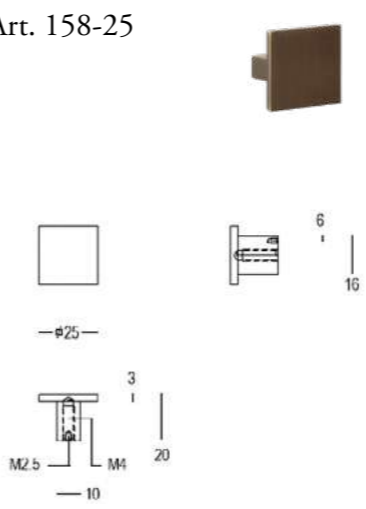

Art. 158-35

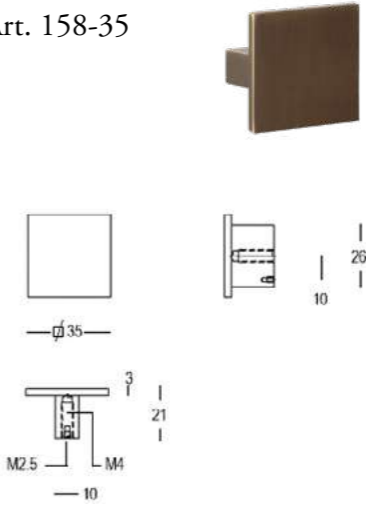

Art. 158-50

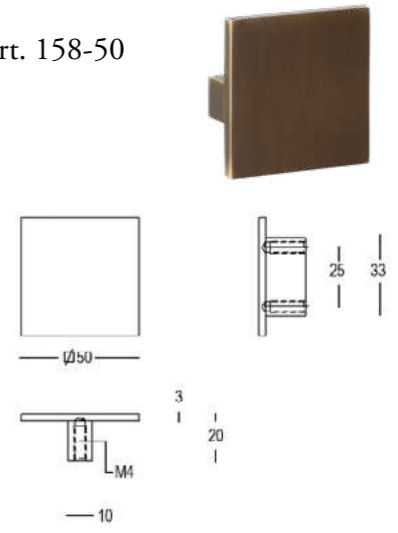

Monaco Art.195-30 (30mm)

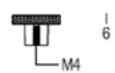

Monaco Art.195-40 (40mm)

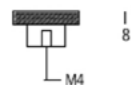
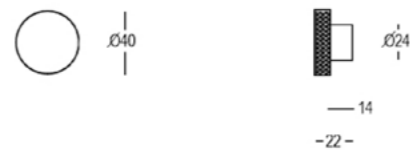

Cassis Art.196-30 (30mm)



Cassis Art.196-40 (40mm)

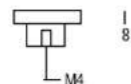
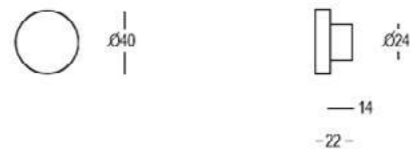

Art. 690-30

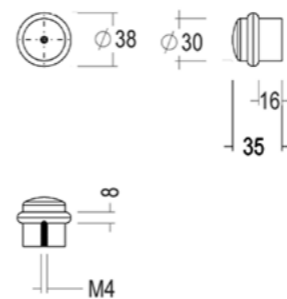

Art. 691-DS

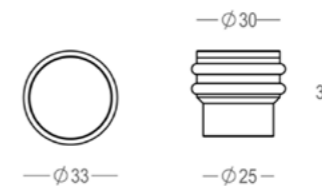

Art.190-DS

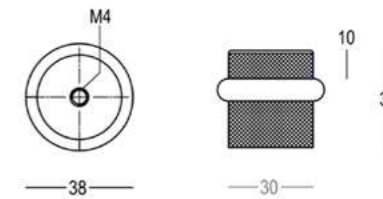

Q 1942



Black textured matt Powder Coat
Laque poudre noir mat texture
Zwart textuur poederlak
RAL 9005 (60)



dark bronzed
bronze foncé
donker brons
(42)



matt bronze
bronze mat
mat brons
(41)



bright bronze
bronze brillant
brons b4
(04)



Rust textured matt Powder Coat
Rouille Laque poudre texture
Roest textuur poederlak
(63)



antique brass
laitron antique
atm
(26)



satin brass
laitron satiné
messing satijn
(22)



bright brass
laitron brillant
messing glanzend
(01)



white textured matt powder coat
laque poudre blanc mat texture
wit mat textuur poederlak
RAL 9016 (65)



antique gun finish
antique étin
TIN
(96)



satin nickel
nickel satiné
satijn nikkel
(99)



bright nickel
nickel brillant
blinkend nikkel
(09)

 indoor & outdoor use
utilisation intérieure et extérieure
voor binnen en buitengebruik



 aluminium anodized natural
aluminium anodisé naturel
Smoke
(50)



Quincalux NV
Kouterstraat 7, 8560 Wevelgem, Belgium

T +32 (0)56 43 53 63
F +32 (0)56 43 53 60

sales@quincalux.com
www.quincalux.com
[@quincalux](https://www.instagram.com/quincalux)

DOWNLOAD
CATALOGUE

